



Captair

Smart

Ductless filtering chemical storage cabinets



Erlab's unique Flex Filtration can manage most lab storages

SMART TECHNOLOGY
 Simple, intuitive communication by light shows the status of the unit

Sensors to detect filter saturation

Low power consumption. Operates with a standard plug using only 45W

Sensors alert the user if the door is left open

Smart 7-inch HD touch screen to fully monitor and access the performance of Erlab storage cabinets (optional).

Smart lock with RFID card

Clear doors for easy viewing



Remote control to monitor the Smart storage cabinets, change the settings, and deliver safety alerts immediately.

4 Adjustable feet inside

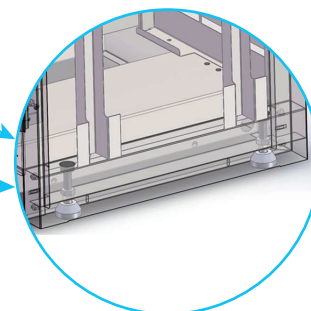

Life in the laboratory becomes simpler and safer

Erlab's 50 years of expertise in research, design and manufacturing of filtering fume hoods and chemical storage cabinets guarantee superior filtration that will keep you protected during your chemical processes.

Smart Technology: The new Captair Smart filtering chemical storage cabinets are designed with a simple and innovative way of communication. Smart Technology uses simple light to show that the unit is operating safely so you can focus your attention on what is most important: your work.



50 years of Erlab's expertise in chemicals filtration



Easy safety communication through light and beeps



Remote access to hood status and alerts



Full compliance with the international safety standards



High level of after-sale service

Simpler to use

- Smart Technology enables visual light communication to indicate the status of the hood. When the light is still the chemical storage cabinets safely. To alert you, the light will pulse. A simple light pattern will indicate if :
 - Fan Failure
 - Filter breakthrough
 - Doors are left open
- The eGuard App gives you remote control to monitor the chemical storage cabinets, change the settings, and delivers safety alerts immediately to your mobile, tablet or PC device.

Safer to operate

- The configurable filtering system above the enclosure can be adapted to filter gases, solvents, powders and particulates keeping the user and the lab protected by safely and efficiently recirculating air within the room and releasing purified air back into the room free of any toxic hazardous vapors or odors.
- Meets AFNOR NFX 15 211/SEFA 9 filtration efficiency standard (classes 1 and 2).
- New sensors are added for detection of solvents or acids or formaldehyde.
- New sensors are added if doors are left open.
- ESP Program: Usage certification delivered with each unit after approval of your storages by our in-house lab.

Organize your chemical storage

- Smaller sizes are available for use on or under counters or equipment.
- Floor-standing models can be configured with adjustable spill-proof shelves, pull-out vertical shelves, and large volume drawers.

A range of floor standing and under bench cabinet

Captair® 632A Midcap*



Sliding doors

Captair® 632B Midcap/Smart*



Sliding doors



Sliding shelf

Captair® 834 Smart



With spill-proof shelves

Captair® 1634 Smart



With spill-proof shelves

Not available for Smart Technology

RANGE OF CAPTAIR SMART (Filtering storage cabinets)	Captair® 632B Midcap/Smart*		Captair® 834 Smart	Captair® 1634 Smart
	Sliding doors	Sliding shelf		
Storage capacity (500ml / bottles)	About 48 x 500ml*	About 30 x 500ml and About 72 x 50 ml	About 66 x 500ml	About 320 x 500ml
External dimensions (mm) (LxDxH)	603x465x686	654x575x715	654x568x715	900x653x2138/2323

Safety solutions for a variety of applications !



GreenFumehoods
an alternative to
ducted fume hoods



Smart Fume Hoods
for your routine
handlings



Captair Smart
Weighing Stations



Captair Smart
Storage cabinets

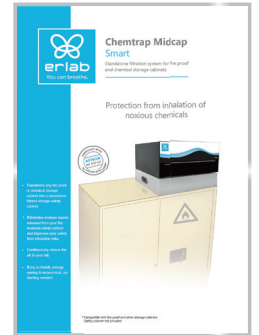

Chemtrap Midcap
Filtration System



Captair Flow
Clean Air Enclosures



Captair Bio
PCR Workstations



Captair Pyramid
Portable Glovebox



Halo
Laboratory Air
Filtration system



Halo Sense
Lab Air Quality Sensor

Europe

erlab D.F.S S.A.S (France)
Parc d'Affaires des Portes
BP 403
27104 Val de Reuil Cedex - France
Tel. : +33(0)2 32 09 55 80
Fax. : +33(0)2 32 09 55 90
E-Mail : Ventes@erlab.net

North America

erlab, Inc. (USA)
388 Newburyport Turnpike
Rowley, MA 01969 - USA
Tel. : +1(978) 948-2216
Fax. : +1(978) 948-3354
E-Mail : CaptairSales@erlab.com

Asia, Middle East, Africa, South America Kunshan erlab D.F.S Co.,Ltd

Tel. : +86 (0)512 5781 4085
Fax. : +86 (0)512 5781 4082
E-Mail : erlab-sales@erlab.net

